

**IKA Transesterification Process**

**Biodiesel Plant**  
**Biodiesel Reaction Process**  
*Continuous Decant, no centrifuges*

**Example: 15,000,000 Gal per Year**

**F.A.M.E. = 98.59 before wash process**  
**F.A.M.E. = 99.85 after wash process**

[www.ikausa.com/biodiesel.htm](http://www.ikausa.com/biodiesel.htm)

### IKA Skid Mounted Primary Process

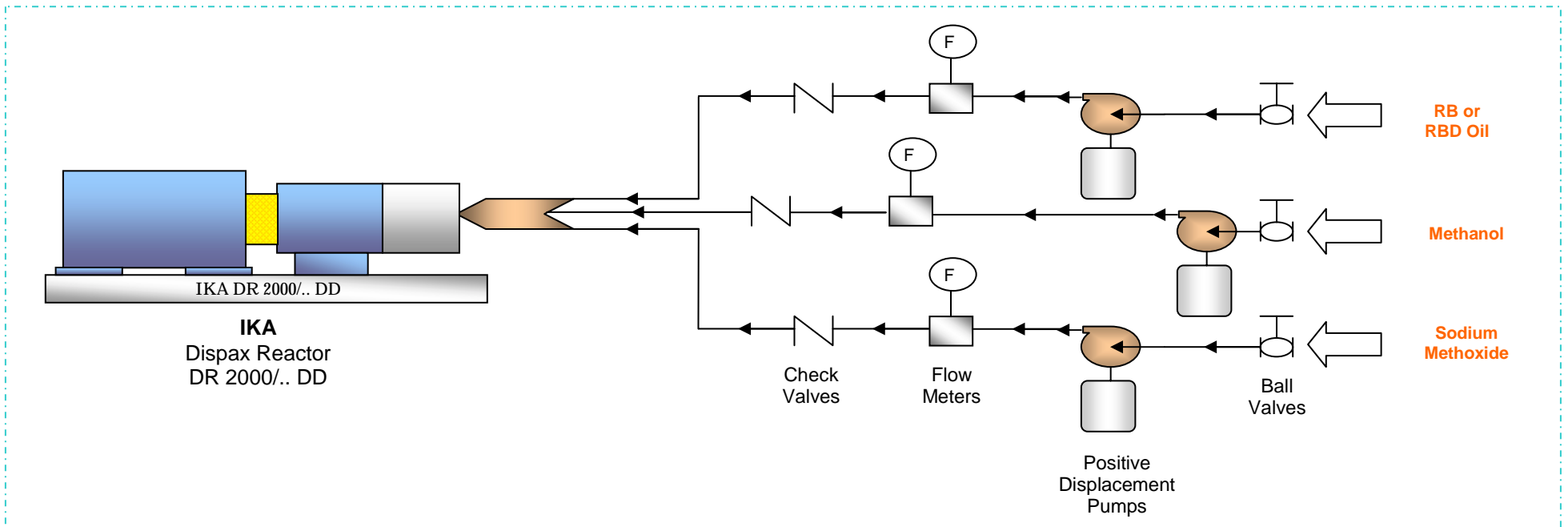

### IKA Skid Mounted Secondary Process

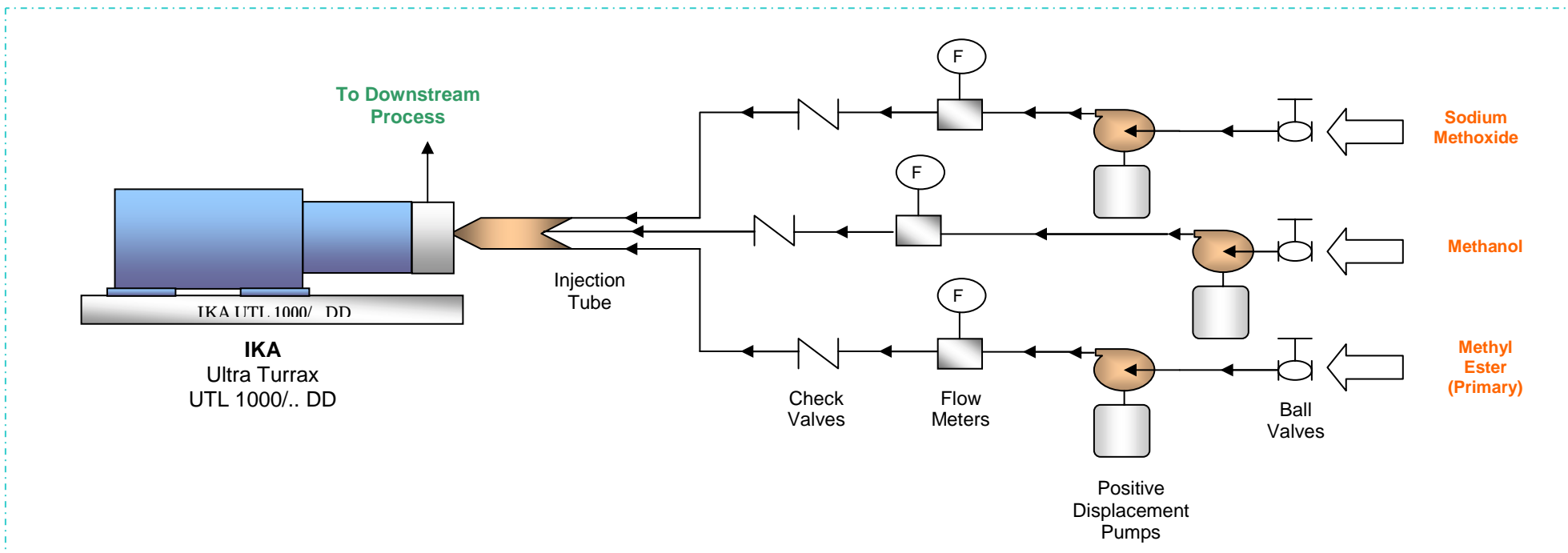

### **Make Use Of Our Multiple Services:**

- Design and fabrication of complete production systems
- Trial machines for on site testing
- Pilot plant test facility in Wilmington, N.C.
- Repair and service work on site or at our facility in Wilmington, N.C.
- Spare parts within 24 hours for most parts
- Start up assistance

*IKA® - Proudly manufactures in The USA*



### **The IKA® Philosophy:**

IKA® is one of the leading manufactures of mixing and dispersing machines employing approximately 450 people worldwide. 70 of these are at our facility in Wilmington, N.C. 10% of our total personnel are engaged in the field of research and development.

An IKA® product means a combination of the latest, innovative technology and highest quality. The use of an IKA® machine or system must be economically justified but at the same time must guarantee a constant product quality over a long period of time with guaranteed results.

We carefully establish a clear plan to determine which machines or systems are most suitable for each and every application. Our philosophy is "The product to be processed and the production time have to be matched in order to achieve the optimum result".